

Med Proto:45 hjulsæt:

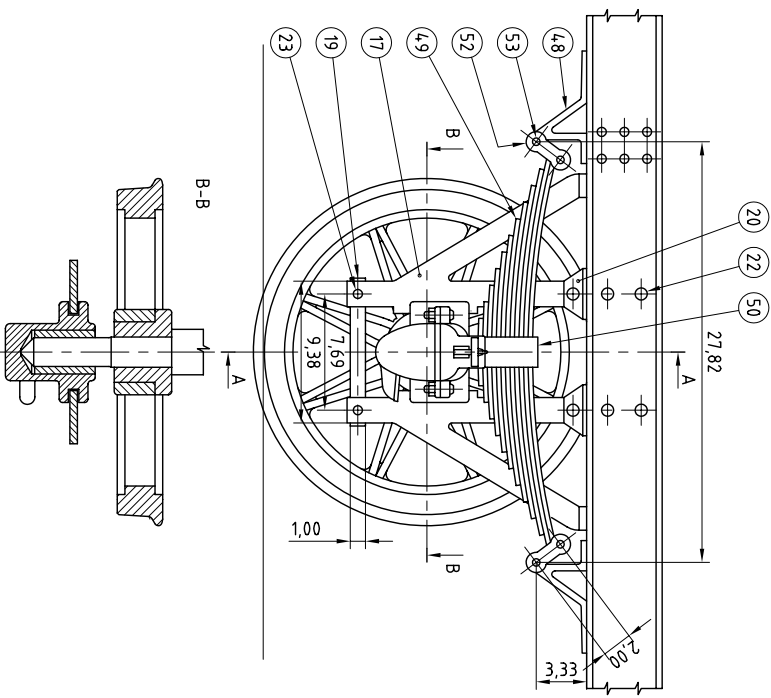

Med 0-Scale Models hjul på nye aksler:

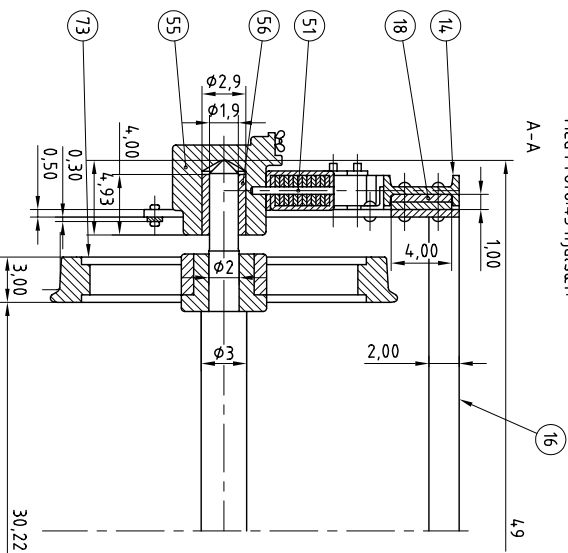
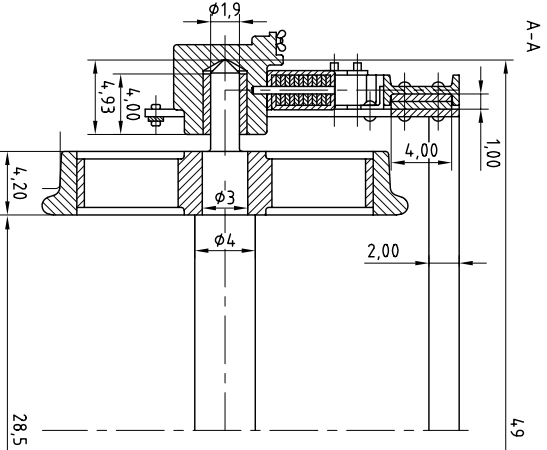

Med 0-Scale Models hjulsæt, aksel modificeret:

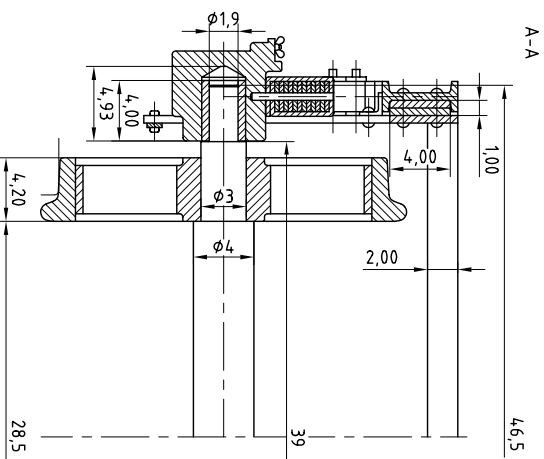

Med 0-Scale Models hjulsæt, aksel ikke modificeret:

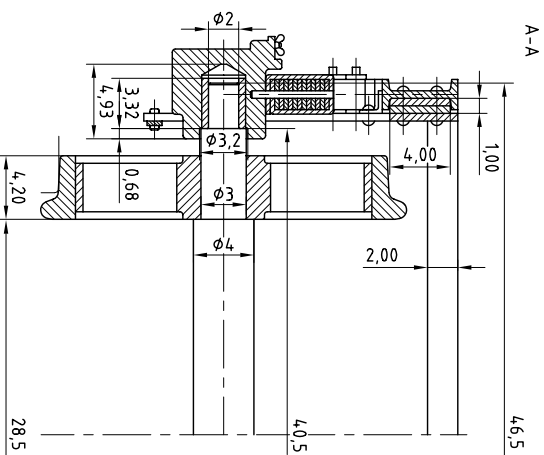

Proto:45 Models
 v/ Erik Olsen
 Tranebakken 52, DK-2635 Ishøj

DSB QD 3908-3958, 9001-9160, 9256-9424,
 3784-3838, 8794-9000, 32839-33413
 Hjulsæt og ophæng

Målforhold	Tegn.	EO	080899
2:1	Kontr.	EO	210800
	Godk.	EO	210800

Tegning nr.:
QD-10005-2